

ESL4805-2111

SLED Butterfly 1480nm

Revision: 2.0
Date: 04-12-2012

Prepared by: Raffaele Rezzonico
(Product Support Technician)

Checked by: Chris Armistead
(Engineering Manager)

Approved by: Philippe Crépellière
(Quality Manager)

Authorized by: Marcus Duell
(CTO)

CONTENTS

1.	SCOPE.....	3
	1.1 PURPOSE	3
	1.2 RESPONSIBILITY	3
2.	REFERENCE DOCUMENT	3
3.	ELECTRO-OPTICAL PERFORMANCE (T_{SLED} = 20°C)	3
4.	ABSOLUTE MAXIMUM RATINGS	4
5.	SCREENING	4
6.	PACKAGE DIMENSIONS [MM]	5
7.	FIBRE AND CONNECTOR.....	5
8.	IMPORTANT NOTES.....	6
9.	ORDERING INFORMATION.....	6
10.	REVISION HISTORY	7

1. SCOPE

1.1 PURPOSE

The purpose of this document is to specify the electro-optical performance and dimensions of superluminescent light emitting diode (SLED) Butterfly.

1.2 RESPONSIBILITY

EXALOS is responsible for establishing, implementing and maintaining this procedure. The Quality representative shall ensure that a timely Engineering Change Notice (ECN) is issued in accordance with EXALOS procedure for any changes.

2. REFERENCE DOCUMENT

- EXS-WI-0001 Visual Inspection Criteria SLED Chip on Submount Procedure
- MIL STD 883 C method.
- Bellcore GR-468-CORE.

3. ELECTRO-OPTICAL PERFORMANCE ($T_{SLED} = 20^{\circ}C$)

Parameter	Symbol	Cond.	Min	Typ	Max	Unit
Operating Current	I_{op}		0		300	mA
Power in SMF	P_o	$I_{op,max}$	1	2		mW
Center Wavelength	λ_c	$I_{op,max}$	1460	1480	1500	nm
Bandwith FWHM		$I_{op,max}$	50	60		nm
Spectral ripple [RB=0.1nm]		$I_{op,max}$		0.1	0.2	dB
Monitor Diode Current *	I_{MPD}		0.1			mA
Monitor diode bias voltage	V_{Bias}		0		-2	V

* Measurement conditions:

- $I_{op} = I_{op, Max}$
- Monitor PD bias voltage: 0 Volts

Input resistance of the Monitor PD current measurement circuit 10 Ohm

4. ABSOLUTE MAXIMUM RATINGS

Stresses beyond the absolute maximum ratings may cause permanent damage to the device. Exposure to absolute maximum rating conditions for extended periods may affect device reliability.



Parameter	Symbol	Cond.	Min	Max	Unit
Forward current	I_F	$I_{F,max}$		350	mA
Reverse voltage	V_R			-2	V
Forward voltage	V_F	$I_{F,max}$		2	V
Storage temperature	T_{stg}		-40	85	°C
Operating temperature	T_{op}	$I_{F,max}$	-20	65	°C
Storage humidity	<30°C >30°C		5	95 85	% r.h. % r.h.
Thermoelectric cooler voltage	V_{tec}			4.0	V
Thermoelectric cooler current	I_{tec}			1.8	A
Thermistor Resistance	R_{th}	20°C	12.5		KΩ
Thermistor constant	B		3892		K
Lead soldering temperature				260	°C
Lead soldering duration				10	s
ESD		human b.m		500	V

5. SCREENING

The produced 1480nm SLED Module is required to meet all operating conditions specified in Table 3, Electro-Optical Performance Specifications after being subjected to the following screening tests.

Test Item	Test Conditions	Reference
Seal	Fine: Condition A1 Gross: Condition C	MIL-STD-883, Method 1014
Temperature Cycling	-40°C to +85°C, ramp rate $\geq 5^\circ\text{C}/\text{min}$ 10 cycles	MIL-STD-883, Method 1010

6. PACKAGE DIMENSIONS [mm]

3rd Angle projection  
Tolerances : .X ± 0.25 mm
.XX ± 0.05 mm

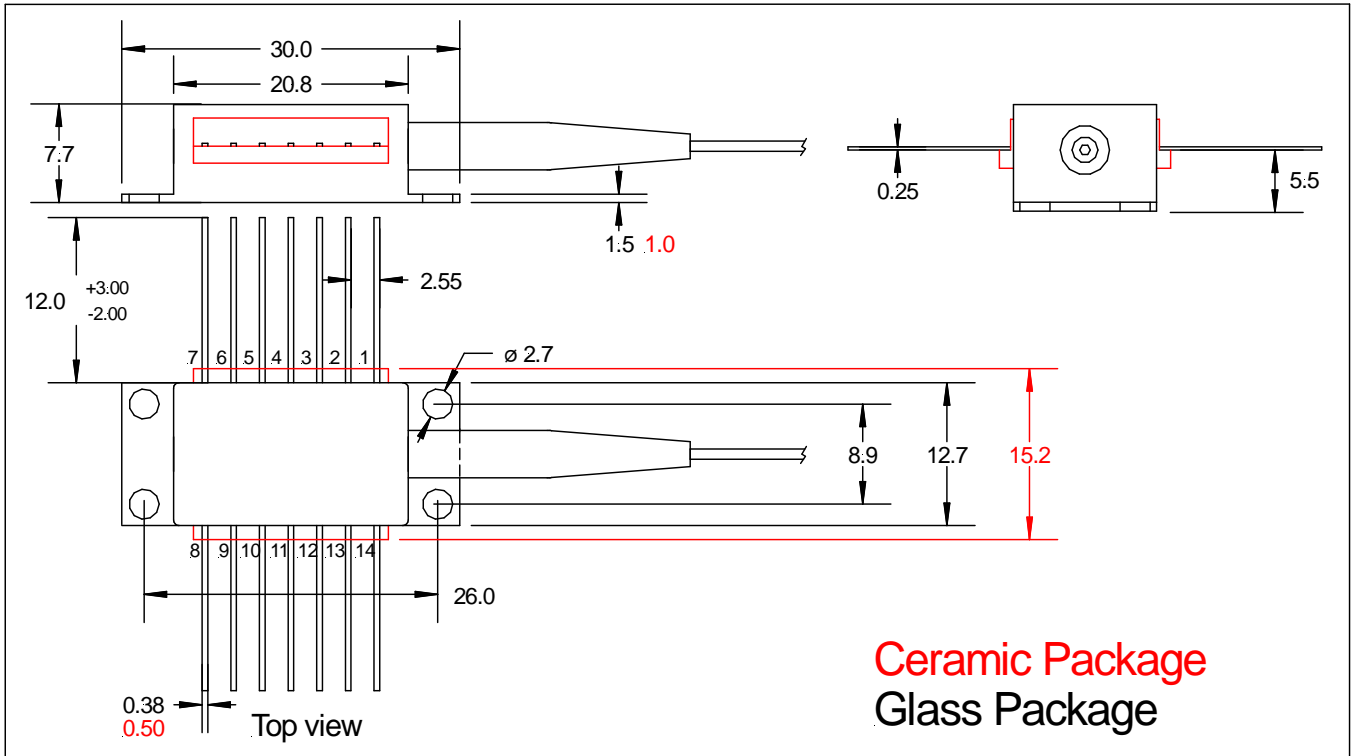

Butterfly Package			
Pin	Function	Pin	Function
1	TEC (+)	8	NC
2	THERMISTOR	9	NC
3	MONITOR DIODE ANODE	10	SLED ANODE (+)
4	MONITOR DIODE CATHODE #	11	SLED CATHODE (-) #
5	THERMISTOR	12	NC
6	NC	13	CASE GROUND
7	NC	14	TEC (-)

Note #: Pin # 4 and Pin # 11 are short-circuited

7. FIBRE AND CONNECTOR

Part	Description
SM Fibre	SMF-28, 9/125 µm
Tight buffer secondary coating	900 µm
Fiber pigtail length [min]	1 m
Optical connector	FC/APC Narrow Key (2.0mm)

Attention: Prior to connecting the SLED module to the driver using constant power mode, make sure that your SLED driver supports the so-called “Common laser cathode/photodiode cathode” arrangement and the connections are set accordingly. If this is not the case do not connect the SLED, otherwise it may result in permanent damage to the SLED.

8. IMPORTANT NOTES

1. Avoid electrostatic discharges, which may destroy the SLED.
2. Never use the bare die without heat sinking.
3. Adequate eye protection against laser radiation should be used while handling and operating the module.
4. EXALOS declines any responsibility if the device is used in applications where human life may be endangered.
5. Back reflections may influence the output power and spectral characteristics of the SLED. The use of optical isolators and/or angled connectors is recommended. Back reflections of less than -30dB are recommended.
6. The measured optical spectrum of the 1480nm shows strong absorption lines in the wavelength range from 1340nm to 1490nm which are believed to origin from absorptions in the atmosphere.

9. ORDERING INFORMATION

Please use the following code system to order products from EXALOS:

Standard product: The Standard product is **ESL4805-2111**.

